

DPX-19879

Baudouin Generator

Prime: 472KW/590KVA

Standby: 520KW/650KVA

Technical Data

Model		650kva
Prime power	kva	590
	kw	472
Standby power	kva	650
	kw	520
Rated voltage line to line	V	400
Rated current	A	852
Maximun sound level for silent	dB@7m	75

Engine-Baudouin

Model		6M33G660/5
Aspiration		4 stroke,6 cylinders,In line, turbocharged and after cooled
Cylinder/Valve		6/24
Displacement	L	19,6
Bore*Stroke	mm	150x185
Compression ratio		15:1
Rated speed	r/min	1500
Engine dimension	mm	2575x1310x1732
Governor		Electrical
Engine wet weight	kg	2435
Engine idel speed		750±20
Piston speed	m/s	9,25
Start Motor	V	24

Exhaust System

Max exhaust back pressure	mbar	75
Standard exhaust pipe diameter	mm	200

Air intake System

air flow	m ³ /min	38,7
Min diameter of intake pipe	mm	140

Fuel System

110% load(Standby power)	L/h	139,3
100% load(Prime power)	L/h	126,5
75% load(Prime power)	L/h	94,1
50% load(Prime power)	L/h	63,6
25% load(Prime power)	L/h	35,5
Fuel capacity for silent genset	L	1100
Fuel capacity for open genset	L	without

Lubrication System

Oil capacity low-high	L	36--61
oil pressure in idle speed	bar	4--6.5
oil flow	L/min	263
Lowest oil pressure alarm	Bar	2
Oil capacity	L	64

Cooling System

Min inside coolant outlet pipe	mm	84
Coolant capacity in radiator&pipe	L	35,6
Coolant alarm temperature	°C	108
Coolant capacity in engine	L	44

Standard Features

Engine(Baudouin ENGINE)	●
Radiator 50°C max,fans are driven by belt	●
24V charge alternator	●
Alternator: single bearing alternator IP23	●
insulation class H/H	●
Standard auto control system	●
One set of air filter, fuel filter, oil filter	●
Main line circuit breaker / ACB	●
Base fuel tank	●
24V batteries, rac and cable	●
Exhaust system(Ripple flex exhaust pipe)	●
Exhaust siphon, flange, muffler	●
User manual	●
Battery charge	●
Water heater	●

Options

- Alternator heater
- PMG
- Water oil separator
- Daily fuel tank
- Remote control panel
- Automatic transfer switch/ATS
- Switch box
- Standard: ● Options: ○

Alternator

Model		TAL-A473-E
Alternator Brand		Leroy Somer
Phase		3
Voltage	V	400
Wiring Type		6 wires
Bearing		1
Power factor		0,8
Frequency	Hz	50
Prime power	KVA	600
Exciter Type		Brushless, self-excitation
Voltage regulation	%	±0.5
Protection Grade		IP 23
Insulation grade		H

Controller-Deepsea

- Model
- 7 configurable digital inputs
- Built-in governor and AVR control
- Base load (kW export) functionality
- Mains (utility) de-coupling protection
- Generator power (kW, kVA) monitoring
- Overload (kW & kV Ar) protection
- Emergency stop
- Start failure

DSE 7320



Unit Dimensions(Basic unit)

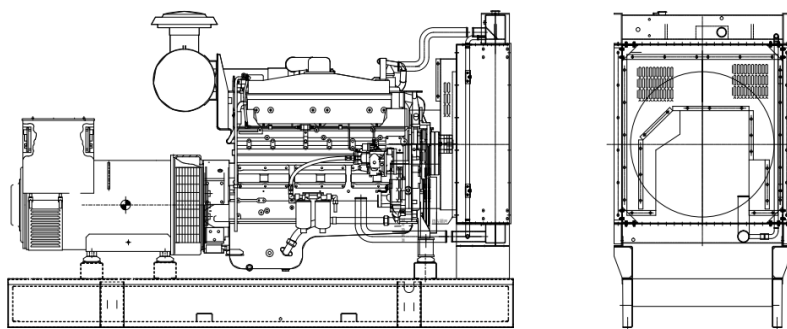

Open Type

L*W*H	mm	4000*1800*2250
Weight	kg	4800

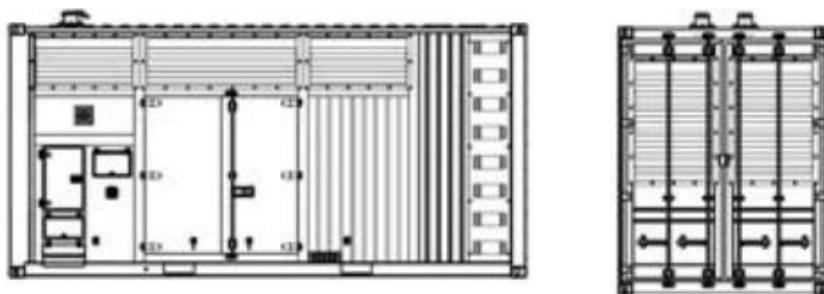

Silent Type

L*W*H	mm	5000*2150*2500
Weight	kg	5800

Warranty

Baudouin Engine

12 months from date of purchase or 1000 hours.

Generator

12 months from date of purchase or 1000 hours

(whichever comes first).