



P18-6

Output Ratings

Voltage, Frequency	Prime	Standby
400V, 50 Hz	16.5 kVA / 13.2 kW	18.0 kVA / 14.4 kW
480V, 60 Hz	20.0 kVA / 16.0 kW	22.0 kVA / 17.6 kW

Ratings at 0.8 power factor.

Please refer to the output ratings technical data section for specific generator set outputs per voltage.

Prime Rating

These ratings are applicable for supplying continuous electrical power (at variable load) in lieu of commercially purchased power. There is no limitation to the annual hours of operation and this model can supply 10% overload power for 1 hour in 12 hours.

Standby Rating

These ratings are applicable for supplying continuous electrical power (at variable load) in the event of a utility power failure. No overload is permitted on these ratings. The alternator on this model is peak continuous rated (as defined in ISO 8528-3).

Standard Reference Conditions

Note: Standard reference conditions 25°C (77°F) Air Inlet Temp, 100m (328 ft) A.S.L. 30% relative humidity.

Fuel consumption data at full load with diesel fuel with specific gravity of 0.85 and conforming to BS2869: 1998, Class A2.

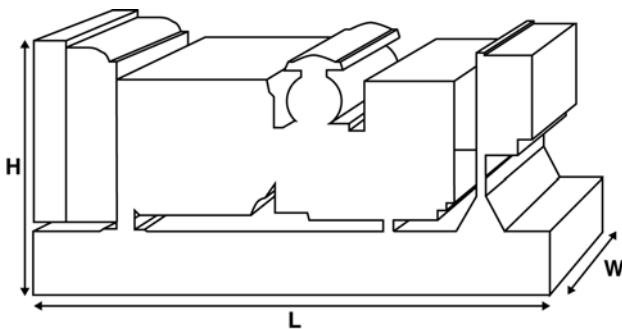

Ratings and Performance Data

Engine Make & Model:	Perkins® 404D-22G1	
Alternator manufactured for FG Wilson by:	Leroy Somer	
Alternator Model:	LL1114H	
Control Panel:	DCP-10	
Base Frame:	Heavy Duty Fabricated Steel	
Circuit Breaker Type:	3 Pole MCB	
Frequency:	50 Hz	60 Hz
Engine Speed: RPM	1500	1800
Fuel Tank Capacity: litres (US gal)	66 (17.4)	
Fuel Consumption: l/hr (US gal/hr)		
(100% Load)	- Prime	4.4 (1.2) 5.2 (1.4)
	- Standby	4.8 (1.3) 5.7 (1.5)

Available Options

FG Wilson offer a range of optional features to tailor our generating sets to meet your power needs. Options include:

- Upgrade to CE Certification
- A wide range of Sound Attenuated Enclosures
- A variety of generating set control panels
- Additional alarms and shutdowns

For further information on all of the standard and optional features accompanying this product please contact your local Dealer or visit: www.FGWilson.com

Dimensions and Weights

Length (L) mm (in)	Width (W) mm (in)	Height (H) mm (in)	Dry kg (lb)	Wet kg (lb)
1500 (59.1)	620 (24.4)	1115 (43.9)	434 (957)	441 (972)

Dry = With Lube Oil

Wet = With Lube Oil and Coolant

Ratings in accordance with ISO 8528, ISO 3046, IEC 60034, BS5000 and NEMA MG-1/22. Generating set pictured may include optional accessories.

Engine Technical Data	
No. of Cylinders / Alignment:	4 / In Line
Cycle:	4 Stroke
Bore / Stroke: mm (in)	84.0 (3.3)/100.0 (3.9)
Induction:	Naturally Aspirated
Cooling Method:	Water
Governing Type:	Mechanical
Governing Class:	ISO 8528
Compression Ratio:	23.3:1
Displacement: l (cu. in)	2.2 (135.2)
Moment of Inertia: kg m ² (lb/in ²)	2.72 (9308)
Engine Electrical System:	
- Voltage / Ground	12/Negative
- Battery Charger Amps	65
Weight: kg (lb)	
- Dry	242 (534)
- Wet	251 (554)

Performance	50 Hz	60 Hz
Engine Speed: rpm	1500	1800
Gross Engine Power: kW (hp)		
- Prime	16.2 (22.0)	19.4 (26.0)
- Standby	18.0 (24.0)	21.5 (29.0)
BMEP: kPa (psi)		
- Prime	585.0 (84.8)	583.0 (84.6)
- Standby	649.0 (94.2)	647.0 (93.8)

Fuel System				
Fuel Filter Type:	Replaceable Element			
Recommended Fuel:	Class A2 Diesel			
Fuel Consumption: l/hr (US gal/hr)				
	110%	100%	75%	50%
Prime	Load	Load	Load	Load
50 Hz	4.8 (1.3)	4.4 (1.2)	3.4 (0.9)	2.6 (0.7)
60 Hz	5.7 (1.5)	5.2 (1.4)	4.0 (1.1)	3.1 (0.8)
	110%	100%	75%	50%
Standby	Load	Load	Load	Load
50 Hz	4.8 (1.3)	3.7 (1.0)	2.7 (0.7)	
60 Hz	5.7 (1.5)	4.4 (1.2)	3.3 (0.9)	

(Based on diesel fuel with a specific gravity of 0.85 and conforming to BS2869, Class A2)

Air Systems	50 Hz	60 Hz
Air Filter Type:	Replaceable Element	
Combustion Air Flow: m ³ /min (cfm)		
- Prime	1.5 (51)	1.7 (61)
- Standby	1.5 (51)	1.7 (61)
Max. Combustion Air Intake Restriction: kPa (in H ₂ O)	3.0 (12.0)	3.0 (12.0)

Cooling System	50 Hz	60 Hz	
Cooling System Capacity: l (US gal)	6.5 (1.7)	6.5 (1.7)	
Water Pump Type: Centrifugal			
Heat Rejected to Water & Lube Oil:			
kW (Btu/min)	- Prime	13.7 (779)	15.5 (881)
	- Standby	15.2 (864)	17.2 (978)
Heat Radiation to Room: Heat radiated from engine and alternator			
kW (Btu/min)	- Prime	4.8 (273)	5.4 (307)
	- Standby	5.8 (330)	6.3 (358)
Radiator Fan Load: kW (hp)	0.2 (0.3)	0.4 (0.5)	
Radiator Cooling Airflow: m ³ /min (cfm)	33.0 (1165)	41.4 (1462)	
External Restriction to Cooling Airflow: Pa (in H ₂ O)	125 (0.5)	125 (0.5)	

Designed to operate in ambient conditions up to 50°C (122°F).
Contact your local FG Wilson Dealer for power ratings at specific site conditions.

Lubrication System	
Oil Filter Type:	Spin-On, Full Flow
Total Oil Capacity: l (US gal)	10.6 (2.8)
Oil Pan: l (US gal)	8.9 (2.4)
Oil Type:	API CH4 15W-40
Oil Cooling Method:	N/A

Exhaust System	50 Hz	60 Hz
Silencer Type: Industrial		
Silencer Model & Quantity: 263-0765 (1)		
Pressure Drop Across Silencer System: kPa (in Hg)	0.70 (0.207)	1.40 (0.413)
Silencer Noise Reduction Level: dB	27	20
Maximum Allowable Back Pressure: kPa (in Hg)	10.2 (3.0)	10.2 (3.0)
Exhaust Gas Flow: m ³ /min (cfm)		
- Prime	3.0 (105)	3.9 (138)
- Standby	3.2 (114)	4.3 (151)
Exhaust Gas Temperature: °C (°F)		
- Prime	364 (687)	396 (745)
- Standby	413 (776)	459 (858)

Documentation

A full set of operation and maintenance manuals and circuit wiring diagrams.

Generating Set Standards

The equipment meets the following standards: BS5000, ISO 8528, ISO 3046, IEC 60034, NEMA MG-1.22.

FG Wilson is a fully accredited ISO 9001 company.

EU Stage IIIA Emissions Compliant.

Warranty

All prime equipment carries a one year manufacturer's warranty. Standby equipment, limited to 500 running hours per year, has a two year manufacturer's warranty. For details on warranty cover please contact your local Dealer, or visit our website: FGWilson.com.

Dealer contact details:

DPX Power

Oostelijke Randweg 20 (Port Nr 114)
4782 PZ – Moerdijk
The Netherlands

www.dpxpower.nl
sales@dpxpower.nl
0031-649905691
0031-631698138



FG Wilson manufactures product in the following locations:

Northern Ireland • Brazil • China • India • USA

With headquarters in Northern Ireland, FG Wilson operates through a Global Dealer Network.

To contact your local Sales Office please visit the FG Wilson website at www.FGWilson.com.

FG Wilson is a trading name of Caterpillar (NI) Limited.

In line with our policy of continuous product development, we reserve the right to change specification without notice.