

Doosan Generator

Prime: 292KW/365KVA
Standby: 320KW/400KVA

Technical Data

Model		400kva
Prime power	kva	373
	kw	298
Standby power	kva	410
	kw	328
Rated voltage line to line	V	400
Rated current	A	537,7
Maximun sound level	dB@7m	75

Engine-Doosan

Model		DP126LB
Aspiration		Four-stroke, water-cooled, 6 cylinders,in line, turbo charged and intercooled
No. cylinders		6
Displacement	L	11,051
Bore*Stroke	mm	125x133
Compression ratio		17.2:1
Rated speed	r/min	1500
Governor		Electrcial system
Engine wet weight	kg	1008
Engine dimension	mm	1426x1096x1295
Fire order		1-5-3-6-2-4
Start Motor	V	24

Exhaust System

Max exhaust back pressure	kPa	5,9
---------------------------	-----	-----

Air intake System

Max inlet pressure (Dirty air)	kPa	6,23
Max inlet pressure (Clean air)	kPa	2,16

Fuel System

110% load(Standby power)	L/h	83,8
100% load(Prime power)	L/h	76
75% load(Prime power)	L/h	57,1
50% load(Prime power)	L/h	38,4
25% load(Prime power)	L/h	20,2
Fuel capacity for silent genset	L	625
Fuel capacity for open genset	L	600

Lubrication System

Idle speed oil pressure	kPa	300
Max oil temperature	°C	120
Oil capacity Max	L	44
Oil capacity Low	L	20

Cooling System

Coolant capacity in engine	L	23
Coolant capacity with radiator	L	51
Thermostat operating range.	°C	82~95
Pressure cap	kPa	90
Coolant Alarm temperature	°C	110

Standard Features

Engine(Doosan Engine)	●
Radiator 50°C max,fans are driven by belt	●
12/24V charge alternator	●
Alternator: single bearing alternator IP23	●
insulation class H/H	●
Standard auto control system	●
One set of air filter, fuel filter, oil filter	●
Main line circuit breaker / ACB	●
Base fuel tank	●
One 12V/Two 24V batteries, rac and cable	●
Exhaust system(Ripple flex exhaust pipe)	●
Exhaust siphon, flange, muffler	●
User manual	●
Battery charge	●
Water heater	●

Options

Alternator heater	<input type="radio"/>
PMG	<input type="radio"/>
Water oil separator	<input type="radio"/>
Daily fuel tank	<input type="radio"/>
Remote control panel	<input type="radio"/>
Automatic transfer switch/ATS	<input type="radio"/>
Switch box	<input type="radio"/>
Standard: ●	Options: ○

Alternator

Model		TAL-A46-H
Alternator Brand		LERROY SOMER
Phase		3
Voltage	V	400
Wiring Type		6 wires
Bearing		1
Power factor		0,8
Frequency	Hz	50
Prime power	KVA	365
Exciter Type		Brushless, self-excitation
Voltage regulation	%	±0.5
Protection Grade		IP 23
Insulation grade		H

Controller-Deepsea

Model	DSE 7320
7 configurable digital inputs	
Built-in governor and AVR control	
Base load (kW export) functionality	
Mains (utility) de-coupling protection	
Generator power (kW, kVA) monitoring	
Overload (kW & kV Ar) protection	
Emergency stop	
Start failure	



Unit Dimensions(Basic unit)

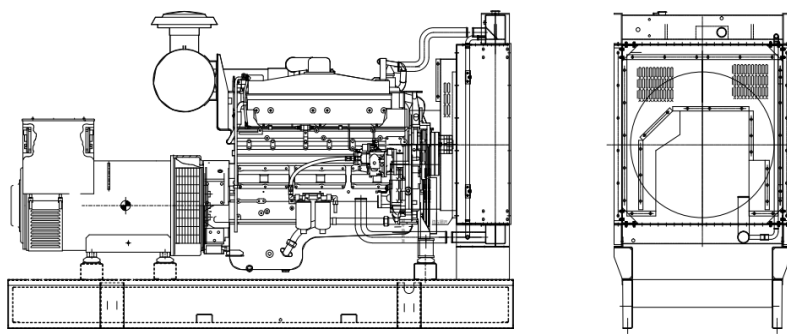

Open Type

L*W*H	mm	3200*1200*1650
Weight	kg	3200

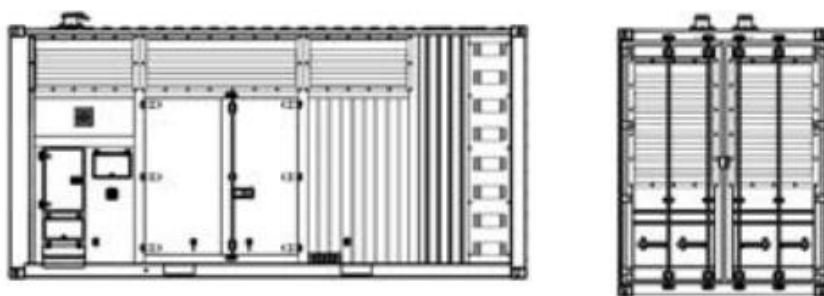

Silent Type

L*W*H	mm	4150*1400*2100
Weight	kg	3600

Warranty

Doosan Engine

12 months from date of purchase or 1000 hours.

Generator

12 months from date of purchase or 1000 hours

(whichever comes first).