

Doosan Generator

Prime: 728KW/910KVA
Standby: 800KW/1000KVA

Technical Data

Model		1000kva
Prime power	kva	910
	kw	728
Standby power	kva	1000
	kw	800
Rated voltage line to line	V	400
Rated current	A	1313,5
Maximun sound level	dB@7m	78

Engine-Doosan

Model		DP222CC
Aspiration		Four-stroke, water-cooled, 12 cylinders,V type, turbo charged and intercooled
No. cylinders		12
Displacement	L	21,927
Bore*Stroke	mm	128x142
Compression ratio		14.6:1
Rated speed	r/min	1500
Governor		Electrcial system
Engine wet weight	kg	1676
Engine dimension	mm	1658×1593×1701
Fire order		1-12-5-8-3-10-6-7-2-11-4-9
Start Motor	V	24

Exhaust System

Max exhaust back pressure	kPa	5,9
---------------------------	-----	-----

Air intake System

Max inlet pressure (Dirty air)	kPa	6,23
Max inlet pressure (Clean air)	kPa	2,16

Fuel System

110% load(Standby power)	L/h	210
100% load(Prime power)	L/h	190
75% load(Prime power)	L/h	147
50% load(Prime power)	L/h	102
25% load(Prime power)	L/h	62
Fuel capacity for silent genset	L	1500
Fuel capacity for open genset	L	without

Lubrication System

Idle speed oil pressure	kPa	100
Max oil temperature	°C	120
Oil capacity Max	L	75
Oil capacity Low	L	23

Cooling System

Coolant capacity in engine	L	24
Coolant capacity with radiator	L	66
Thermostat operating range.	°C	71~85
Pressure cap	kPa	90
Coolant Alarm temperature	°C	103

Standard Features

Radiator 50°C max,fans are driven by belt	●
12/24V charge alternator	●
Alternator: single bearing alternator IP23	●
insulation class H/H	●
Standard auto control system	●
One set of air filter, fuel filter, oil filter	●
Main line circuit breaker / ACB	●
Base fuel tank	●
One 12V/Two 24V batteries, rac and cable	●
Exhaust system(Ripple flex exhaust pipe)	●
Exhaust siphon, flange, muffler	●
User manual	●
Battery charge	●
Water heater	●

Options

Alternator heater	<input type="radio"/>
PMG	<input type="radio"/>
Water oil separator	<input type="radio"/>
Daily fuel tank	<input type="radio"/>
Remote control panel	<input type="radio"/>
Automatic transfer switch/ATS	<input type="radio"/>
Switch box	<input type="radio"/>
Standard: <input checked="" type="radio"/>	Options: <input type="radio"/>

Alternator

Model		TAL-A49-D
Alternator Brand		LERROY SOMER
Phase		3
Voltage	V	400
Wiring Type		6 wires
Bearing		1
Power factor		0,8
Frequency	Hz	50
Prime power	KVA	910
Exciter Type		Brushless, self-excitation
Voltage regulation	%	±0.5
Protection Grade		IP 23
Insulation grade		H

Controller-Deepsea

Model	DSE 7320
7 configurable digital inputs	
Built-in governor and AVR control	
Base load (kW export) functionality	
Mains (utility) de-coupling protection	
Generator power (kW, kVA) monitoring	
Overload (kW & kV Ar) protection	
Emergency stop	
Start failure	



Unit Dimensions(Basic unit)

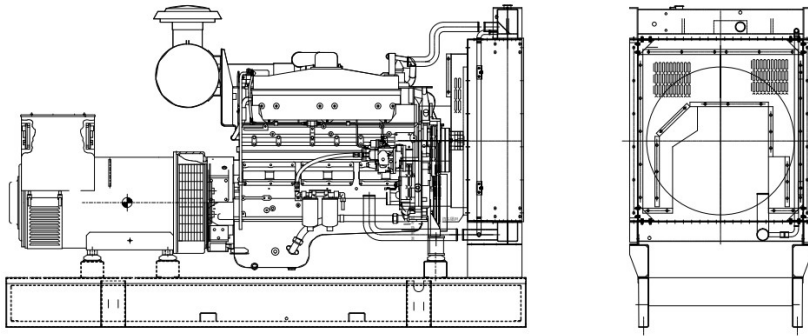

Open Type

L*W*H	mm	4200x1750x2050
Weight	kg	5200

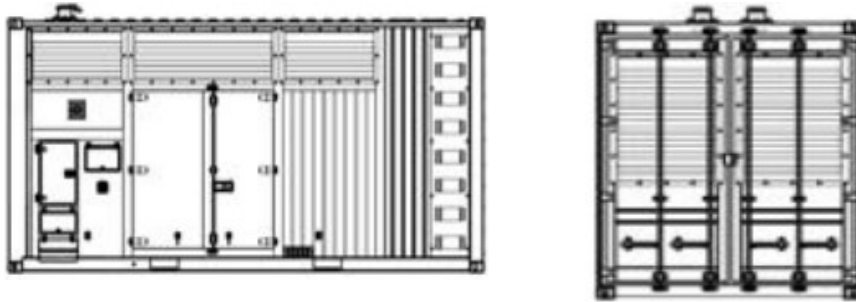

Silent Type

L*W*H	mm	5000x2000x2500
Weight	kg	6200

Warranty

Doosan Engine

12 months from date of purchase or 1000 hours.

Generator

12 months from date of purchase or 1000 hours

(whichever comes first).

